



Design Criteria Manual

Chapter 1: Roads

Public Works Department

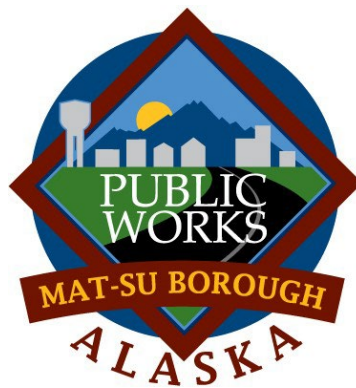

Table of Contents

- 1 ROADS 1-1
 - 1.1 Scope 1-1
 - 1.2 References 1-1
 - 1.3 Functional Classifications..... 1-2
 - 1.4 Traffic 1-3
 - 1.4.1 Traffic Analysis Report 1-3
 - 1.4.2 Traffic Impact Analysis..... 1-3
 - 1.4.3 Traffic Volume Determination 1-3
 - 1.4.4 Peak Hour Trip Generation 1-4
 - 1.4.5 Warrant Analyses 1-4
 - 1.5 Roadway Characteristics 1-5
 - 1.5.1 Arterials 1-5
 - 1.5.1.1 Principal Arterials 1-6
 - 1.5.1.2 Minor Arterials..... 1-6
 - 1.5.2 Collectors..... 1-7
 - 1.5.2.1 Major Collector 1-7
 - 1.5.2.2 Minor Collector..... 1-7
 - 1.5.3 Local 1-9
 - 1.5.3.1 Local – Residential and Residential Subcollector..... 1-9
 - 1.5.3.2 Local – Commercial/Industrial 1-9
 - 1.5.3.3 Local – Pioneer 1-9
 - 1.5.3.4 Local - Mountain..... 1-9
 - 1.5.3.5 Frontage Roads 1-11
 - 1.6 Design Criteria 1-12
 - 1.6.1 General 1-12
 - 1.6.2 Design and Posted Speed 1-12
 - 1.6.3 Horizontal Design Standards 1-12
 - 1.6.4 Vertical Design Standards..... 1-13
 - 1.6.5 Typical Sections 1-13
 - 1.6.5.1 Travelled Way (Lane Width)..... 1-13
 - 1.6.5.2 Shoulder 1-13
 - 1.6.5.3 Clear Zone..... 1-14

1.6.5.4	Ditches	1-14
1.6.5.5	Cut and Fill Slopes.....	1-14
1.6.5.6	Cross Slopes	1-15
1.6.6	Intersections.....	1-15
1.6.6.1	Horizontal	1-15
1.6.6.2	Vertical.....	1-15
1.6.6.3	Curve Returns	1-16
1.6.6.4	Intersection Sight Distance	1-16
1.6.7	Auxiliary Lanes.....	1-18
1.6.8	Supplemental Design Elements.....	1-18
1.6.8.1	Signage.....	1-18
1.6.8.2	Striping.....	1-19
1.6.8.3	Curb and Gutter	1-19
1.6.8.4	Curb Cuts	1-19
1.6.8.5	Medians	1-20
1.6.8.6	Guardrails	1-20
1.6.8.7	Retaining Structures (Non-bridge).....	1-20
1.6.9	Pedestrian Facilities.....	1-21
1.6.9.1	Multi-Use Pathways	1-21
1.6.9.2	Sidewalks	1-22
1.6.9.3	Pedestrian/Vehicle Separations.....	1-22
1.6.9.4	Accessibility Requirements.....	1-22
1.6.10	Access Points.....	1-23
1.6.10.1	Access Point Spacing.....	1-23
1.6.10.2	State Highways.....	1-23
1.6.10.3	Borough Roads.....	1-23
1.6.11	Utilities	1-23
1.6.12	Lighting.....	1-24
1.6.13	Mailbox Pullouts	1-24
1.6.14	Geotechnical Information	1-25
1.6.15	Requirements for Paved Streets	1-25
1.6.16	Insulation	1-25
1.6.17	Right-of-Way	1-26

1 ROADS

1.1 Scope

This chapter provides functional classifications standards, traffic analysis requirements, right-of-way (ROW) standards and design criteria, for design and construction of all new roads and pathways and upgrades. This manual does not apply to pavement preservation projects.

1.2 References

All reference documents, which are incorporated or incorporated by reference in this Design Criteria Manual (DCM), shall be the latest edition, unless otherwise noted.

The following MSB documents are incorporated for all roadway projects:

- MSB Standard Modifications to the DOT&PF Standard Specifications for Highway Construction
- MSB Standard Drawings

The MSB incorporates the following DOT&PF standards for all roadway projects, unless otherwise noted:

- Standard Specifications for Highway Construction, 2017 Edition
- Standard Modifications
- Standard Special Provisions (Statewide and Regional)
- Alaska Standard Plans Manual (Standard Drawings)
- Alaska Flexible Pavement Design Manual
- Alaska Geotechnical Procedures Manual
- Alaska Traffic Manual
- Construction Surveying Requirements
- Alaska Right-of-Way Manual
- Alaska Sign Design Specifications

The MSB standard modifications to the DOT&PF standard specifications and standard drawings are maintained and available through the PD&E Division. These documents supersede their respective DOT&PF standard specifications and drawings.

The MSB incorporates the following American Association of State Highway and Transportation Officials (AASHTO) documents for guidance:

- A Policy on Geometric Design of Highways and Streets (Green Book (GB))
- Roadside Design Guide
- Very Low Volume Roads
- Guide for the Development of Bike Facilities

1.3 Functional Classifications

The role that a roadway serves within the overall transportation network defines its function. Some roads serve travel over extended distances while others channel traffic to centers of community activity. Other roads primarily provide access to abutting properties. Classification establishes a hierarchy of road function and the mobility versus access character and is used to determine road design standards and roadside development restrictions, such as the typical section, pedestrian amenities and ROW width.

The general roadway classifications consist of arterial, collector, and local roads. Pioneer and mountain access roads are a special classification of local roads to be used only where extreme isolation and topography dictates, respectively. Arterials are designed to carry large volumes of traffic at an efficient speed. Local roads serve the terminal ends of a trip. Collector roads gather and distribute trips between local streets and arterials. This can be encapsulated by defining an arterial’s main function as mobility, a local street’s main function as access, and a collector offering a balance of both access and mobility.

The classification of most MSB roadways is established in the Official Streets and Highways Plan (OSHP), and these classifications should be followed when designating a new project, unless a need for a higher classification is determined by the project’s Traffic Analysis for the design year. Under no circumstances should a project be designed to a lower classification than the one established in the OSHP. When a new roadway without classification is proposed, it shall receive a classification from the MSB, based on projected traffic volume, origin and destination, and other considerations. An individual road may change functional classifications through its length according to differences in existing and projected traffic counts and anticipated use. The table below provides the classification to be used as a function of traffic volume. See section 1.4.3 for additional information.

Table 1-1: Daily Traffic per Functional Classification

Functional Classification	Annual Average Daily Traffic (AADT)
Principal Arterial	More than 10,000
Minor Arterial	5,000 – 10,000
Major Collector	2,000 – 5,000
Minor Collector	600 – 2,000
Local	Less than 600*

**Local commercial and frontage roads may exceed this amount, up to a total of 1,000 vehicles per day (VPD)*

Note: The functional classification of these facilities may also be increased by their intended use with -

1.4 Traffic

1.4.1 Traffic Analysis Report

A Traffic Analysis Report is required as part of any roadway development project that will construct or upgrade a proposed roadway classified as a minor collector or above. Traffic analyses shall be completed by a professional civil engineer licensed in Alaska with experience in traffic studies. Roadway classifications shall be based on the Official Streets & Highway Plan and project scoping documents. The purpose of the traffic analysis is to determine the need for roadway features that control the flow of traffic, such as signals, turns lanes, travel lanes, roundabouts, stop signs, pedestrian crossings, as well as the typical section and clear zone criteria. A Traffic Analysis Report should evaluate traffic forecast for a minimum period of 20 years beyond the year construction is projected to be complete.

Traffic analyses shall include operational analyses of roadways and level of service evaluations for major intersections performed in accordance with the Highway Capacity Manual (HCM), including signal or roundabout warrant analyses shall be conducted in accordance with the Manual on Uniform Traffic Control Devices (MUTCD). Roundabout analysis shall be in accordance with the Transportation Research Board's National Cooperative Highway Research Program (NCHRP) 672 "Roundabouts: An Informational Guide". These analyses should include bicycle and pedestrian use and amenities.

1.4.2 Traffic Impact Analysis

A Traffic Impact Analysis (TIA) is required to be generated by a licensed civil engineer for commercial or institutional (schools, government buildings, etc.) development with greater than 100 trips per peak hour. The civil engineer for the commercial or institutional development shall consult with a Borough Engineer to determine what information is required to be included in the TIA. A TIA should evaluate traffic forecast for the design year, which is a minimum period of 10 years beyond the year construction is projected to be complete. The proposed improvements shall be evaluated and demonstrate a level of service of B or better for the peak hour in the design year.

A TIA shall be completed for developments demonstrating at least 50 vehicles per hour during the peak hour, according to trip generation estimates (refer to section 1.4.4), and must include a warrant analysis, as described in section 1.4.5 to determine the need for signalization and/or turn lanes.

1.4.3 Traffic Volume Determination

Anticipated traffic volumes are important to establish before the design process in order to determine functional classification, and provide adequate roadway features such as number of lanes, shoulder widths, guardrail type, etc. The MSB and DOT&PF maintain a database of traffic volumes based on temporary or permanent counter stations for certain roads, however, not all roads are covered or current. The design engineer shall contact the MSB to determine the availability of traffic data. The designer shall note that some of the available traffic data is average daily traffic (ADT) and some is AADT. For conversion factors from ADT to AADT, contact the MSB PD&E Division. If no data is available, then

existing traffic volumes shall be determined in accordance with the Federal Highway Administration (FHWA) Traffic Monitoring Guide or the FHWA Traffic Data Computation Method Pocket Guide.

Design Designations will be provided by the MSB PD&E Division. Design Criteria shall be developed by the design engineer based on the design designations.

1.4.4 Peak Hour Trip Generation

Peak hour vehicle trips are used to determine the requirements for intersection, approach, and driveway design for both public and private infrastructure development. The design engineer shall determine trip generation from methods established in the latest edition of the Institute of Transportation Engineers (ITE) Trip Generation Manual, except where local trip generation rates have been established, as noted below.

The MSB has conducted trip generation studies for some types of land uses that differ from or are not included in the ITE Trip Generation Manual. Refer to the MSB's Local Trip Generation Studies and Summary Table 1-2 below for local trip generation rates.

1.4.5 Warrant Analyses

A warrant analysis shall be performed as part of either a Traffic Analysis or TIA for all major intersections within a project area, where a signal or roundabout may be required for intersection control. The warrant analysis shall be conducted in accordance with the MUTCD. Roundabout analysis shall be in accordance with the Transportation Research Board's National Cooperative Highway Research Program (NCHRP) 672 "Roundabouts: An Informational Guide". These analyses should include bicycle and pedestrian use and amenities.

Intersections with side roads that have more than 150 vehicles during the peak hour shall be evaluated for both left and right turn lanes. Turn lane warrant analysis shall be performed in accordance with the following guidance:

- Right turn lanes - the 1985 "National Cooperative Research Program Report 279", Figure 4-23 (Transportation Research Board); and
- Left turn lanes – NCHRP Report 745: "Left Turn accommodations at Unsignalized Intersections", or AASHTO'S, A Policy on Geometric Design of Highways and Streets, 2018, Tables 9-24 thru 9-26.

Table 1-2: MSB Local Trip Generation Rates

ITE Land Use Code	Land Use Name		Independent Variable	Valid Values of the Independent Variable	Local Trip Generation Rate		Study Reference
					Per Day	Peak Hour	
N/A	Gasoline/Service Station with Convenience Market and Liquor Store		Vehicle Fueling Position	4 to 15		25.8	Kinney, 2011
N/A	Gasoline/Service Station with Convenience Market and Liquor Store		Gross Floor Area (1000 SF)	4 to 12.5		30.7	Kinney, 2011
210	Single-Family Detached Housing		Dwelling Units	70 to 200	6.89	0.69	Kinney, 2018
221	Low-Rise Apartment		Occupied Dwelling Units	30 to 100		ITE	Kinney, 2011
231	Low-Rise Residential Condominium/Townhouse		Dwelling Units	30 to 100		ITE	Kinney, 2011
522	Middle School/Junior High School						
530	High School						
850	Supermarket		Gross Floor Area (1000 SF)	5 to 70		9.48	Kinney, 2012
854	Discount Supermarket		Gross Floor Area (1000 SF)	5 to 50		8.5	Kinney, 2011
862	Home Improvement Superstore		Gross Floor Area (1000 SF)	12 to 150		3.32	Kinney, 2012

1.5 Roadway Characteristics

1.5.1 Arterials

Arterial roads permit rapid and relatively unimpeded traffic movement throughout the Borough, connecting communities and activity centers. Arterial roads should not bisect neighborhoods but should act as boundaries between them. Local streets should generally not intersect with arterials, but instead with collector roads that then provide access to principal arterials. On-street parking is not allowed on arterial roads. Direct access to abutting private property is not permitted, unless no other access is available to a lower classification road.

1.5.1.1 Principal Arterials

Most principal arterials in the MSB are owned and maintained by the State and are focused primarily on mobility. Regulation of traffic on principal arterials shall be accomplished through the use of traffic signals and channelization. Roundabouts are discouraged due to the high traffic volumes and speeds.

1.5.1.2 Minor Arterials

Minor Arterial roads permit relatively unimpeded traffic movement and long trip lengths. Mobility on arterials is prioritized by limiting access, traffic flow impediments and conflicts. The distance between intersections with intersecting roads should be maximized and should be at least one-quarter (1/4) mile apart, except in cities. Wherever possible, access points should be consolidated, and upgrade projects may include removal of private or public approaches to improve safety and mobility. Regulation of traffic shall be accomplished through the use of signals, roundabouts and channelization. Roundabouts on minor arterials are acceptable, but only at intersections with reasonably balanced traffic flows, where less than 80 percent of the entering traffic is on the mainline, and no approach leg has less than 10 percent. Access from streets with classification lower than a minor collector is discouraged.

Table 1-3: Design Standards – Major/Minor Arterials

Classification	Principal Arterial	Minor Arterial
ROW	140 feet	130 feet
Design Speed	50 - 60+ mph	45 - 60 mph
Road Surface	2 - 4 lanes, 12-foot lanes, paved	2 - 4 lanes, 12-foot lanes, paved
Maximum Superelevation	8%	8%
Maximum Grade	5%	6%
Minimum Grade	0.5%	0.5%
Minimum Flow Line Grade	0.5%	0.5%
Minimum Curve Return Radius	40 feet	40 feet
Striping	Center and edge lines with inlaid Methyl Methacrylate (MMA)	Center and edge lines with inlaid MMA
Access	Restricted to public roadway approaches classified as collector and above, private and commercial access via side, frontage and backage roads	Restricted to public roadway approaches, private and commercial access via side, frontage and backage roads.
Intersection Treatments	Traffic signals with dual left-turn lanes, separated grade interchanges. No roundabouts.	Traffic signals and roundabouts
Median Treatments	Raised or depressed continuous medians. Center-two-way-left-turn lanes allowable in urban areas.	Raised or depressed medians, where needed for traffic control and safety. Center-two-way-left-turn lanes allowable in urban areas.

Shoulder Treatments	4 – 8-foot paved shoulders, bike lanes, no pedestrians in roadway.	4 – 8-foot paved shoulders, bike lanes, no pedestrians in roadway
Pedestrian Treatments	10-foot wide, paved, separated pathways on at least one side of the road. Pedestrian crossings shall be grade separated or signalized. Min. 5-foot sidewalk on opposite side in urban areas. Pathways and sidewalk shall have min. 10-foot separation between edge of pavement and edge of pathway.	10-foot wide, paved, separated pathways. Pedestrian crossings shall be grade separated or signalized. Min. 5-foot sidewalk on opposite side in urban areas. Pathways and sidewalk shall have min. 10-foot separation between edge of pavement and edge of pathway.

1.5.2 Collectors

Collectors are high-volume roads with more traffic than local roads, but lesser mobility requirements than arterial roadways and are designed to carry traffic within communities. Private access is limited as described in this section and shall be in accordance with MSB Code 11.12 for driveway requirements.

1.5.2.1 Major Collector

Major collector streets shall be designed to permit relatively unimpeded traffic movement and are intended for use in commercial/industrial or high-density residential areas. Street parking is not allowed on major collector streets. Access from streets of lower classification will be permitted, but in most cases will be controlled by traffic control devices and should be spaced at no less than one quarter (1/4)-mile. Direct access to abutting property shall be limited to high traffic volume generators, such as commercial/industrial facilities, schools, or other public institutions. Average access point spacing shall conform to the distances provided in Table 1-8. Regulation of traffic shall be accomplished through the use of traffic signs, signals, and channelization. Roundabouts are acceptable, but only at intersections with reasonably balanced traffic flows, where less than 80 percent of the entering traffic is on the mainline, and none of the approach legs has less than 10 percent.

1.5.2.2 Minor Collector

Minor collectors collect and distribute traffic between arterials, major collectors, and local streets and serve as main connectors within communities, linking one neighborhood with another. Minor collectors are generally intended for use in commercial/industrial areas or within residential neighborhoods or to connect smaller neighborhoods. Minor collectors include residential collectors in subdivisions. Average access point spacing shall conform to the distances provided in Table 1-8. Regulation of traffic shall be accomplished through the use of approved traffic control measures. Roundabouts are acceptable at intersections with equal or lower classification roads and at major collectors and minor arterials where the traffic volume criteria for those roads are met.

Table 1-4: Design Standards – Major/Minor Collectors

Classification	Major Collector	Minor Collector
ROW	100 feet	90 feet
Design Speed	35-60 mph	35-50 mph
Road Surface	Paved, 2-lanes, 12-foot lanes	Paved, 2-lanes, 11-foot lanes
Maximum Superelevation	6%	6%
Maximum Grade	7%	8%
Minimum Grade	0.5%	0.5%
Minimum Flow Line Grade	0.5%	0.5%
Minimum Curve Return Radius	40 feet	30 feet
Striping	Centerline and edge lines required	Centerline and edge lines required
Access	Direct private access is limited. Direct commercial or industrial access may be allowed with traffic analysis.	Direct private access is limited based on average spacing and volumes.
Intersection Treatments	Stop Control, traffic signals or roundabouts at arterial or major collector crossings.	Stop control.
Median Treatments	Turn lanes, no medians except at intersections, center-two-way-left-turn lanes.	Turn lanes at intersection with higher function roads, no medians except for traffic calming
Shoulder Treatments	Minimum 4-foot paved shoulders.	Minimum 2-foot paved shoulder.
Pedestrian Treatments	10-foot paved pathway on one side of the road with minimum 10-foot separation between edge of pavement and edge of pathway. Sidewalk on opposite side, as needed. Sidewalks shall be min. 5-foot and have min. 10-foot separation between edge of pavement and edge of pathway.	10-foot paved pathway on one side of the road with minimum 10-foot separation between edge of pavement and edge of pathway. Separation distance may be reduced to 5 feet for roads with a posted speed limit of 35 mph or less, and where ROW acquisition is not practical, as determined by the Public Works Director.
Other Treatments	On-street features such as mailbox pullouts are discouraged.	Speed bumps, transit stops, and mailbox pullouts are allowed.

1.5.3 Local

Traffic carried by local streets primarily should have an origin or a destination within the neighborhood and are designed to discourage through traffic. Local roads are typically accessed from minor collectors or other local roads and can also be designed as cul-de-sacs. This is the lowest level classification of road. They are intended to carry the least amount of traffic at the lowest speed and to provide access to individual properties for motorized vehicles, bicycles, and pedestrians. Whenever possible, local streets should not intersect major collectors or arterial streets.

1.5.3.1 Local – Residential and Residential Subcollector

Local residential roads serve local traffic and have low traffic volumes. Traffic carried by local roads should have an origin or a destination within the neighborhood and are designed to discourage through traffic. Local roads are typically designed to connect to collector roads, although they can also be designed as cul-de-sacs or to provide connectivity to adjacent subdivisions. On-street parking lanes are not allowed.

1.5.3.2 Local – Commercial/Industrial

Local commercial/ industrial streets are intended for commercial/industrial developments. These streets may intersect major collectors in some situations but should not intersect with an arterial road unless no other alternative is available. Backing or loading maneuvers shall not be allowed.

On-street parking lanes are not allowed. Traffic control shall be provided using signage at all intersections. Since designs of commercial/industrial streets are based on the intention of the owner, no specific design criteria or cross-sections are included in this manual.

1.5.3.3 Local – Pioneer

Pioneer roads typically are the initial roads within undeveloped areas and may only be developed where MSB Code allows. Their road status tends to change over time as development progresses around the initial road, thus the need for an increased ROW to allow for future road upgrades.

The design for constructing Pioneer roads consists of a thinner structural section and no surface course. This is to facilitate a less-costly initial-entry type road into an undeveloped area. While a thinner structural section is allowed, the full width at final build-out must be accounted for.

No public maintenance is provided for pioneer roads.

1.5.3.4 Local - Mountain

Mountain access roads may be used in areas where the average cross slope exceeds 15 percent or to traverse terrain features in excess of 25 percent. Public maintenance for mountain roads is at the

discretion of MSB Department of Public Works (DPW). Mountain access road allow for steeper grades and switchbacks, but should otherwise be designed to local residential standards. School bus access should be considered since buses are limited to 10% grades.

Table 1-5: Design Standards – Local Roads

Classification	Local Road			
	Residential	Commercial/Industrial	Pioneer	Mountain
Local Road Type				
Min. ROW width (ft)	60	75	60	80
Design Speed (mph)	30	30	30	25
Posted Speed	25	25	25	20
Road Surface	Paved or unpaved, 2-lanes, 10-foot lanes	Paved, 2-lanes min., 12-foot lanes	Unpaved, 2-lanes min. 10-foot lanes	Paved or unpaved, 2-lanes, min. 10-foot lanes
Maximum Grade	10%	8%	10%	15%
Minimum Grade	0%			
Minimum Curve Return Radius	25 feet	40 feet	20 feet	20 feet
Superelevation	None			
Striping	No striping required on centerline or edge line, except as required for lane control (i.e., turn lanes, roundabouts).			
Access	Encouraged (Residential and Commercial)			
Intersection Treatments	Stop control, no traffic signals expected			
Median Treatments	Optional for traffic calming, landscaping, grading, and drainage or at intersections			
Minimum Shoulder	2-foot unpaved	2-foot unpaved	None required	2-foot unpaved.
Pedestrian Treatments	Optional sidewalks pathways, or paved shoulders	Optional pathways, sidewalks, bike lanes. No paved shoulders for pedestrian use	None	Optional sidewalks, pathways, or paved shoulders
Other Expectations	Speed bumps, transit stops, mailbox pullouts, cul-de-sacs, mini-roundabouts are allowed			

1.5.3.5 Frontage Roads

Frontage streets are required as an alternative to allowing access to or from lots along existing or proposed major collectors or higher classification streets. Frontage streets shall be classified and designed to conform to the design standards and restrictions of a residential or commercial local or collector road as determined by the anticipated use, speed, and ADT. The following section provides minimum separation distances, however, more space may be needed as determined by traffic analysis. The design year traffic volumes, turning movements, vehicle storage, and signal phasing should all be analyzed when determining the separation distance.

Separation Distances

Minimum ROW to ROW separation distance between major corridors and frontage or backage roads shall be:

- (a) 0 feet for locations with no connector street to the major road corridor;
- (b) 100 feet for locations with a connector street to the major road corridor that lie between section lines and planned or existing intersections with other major road corridors;
- (c) 300 feet for locations where the connector street to the major road corridor is on a section line or planned or existing major road corridor.

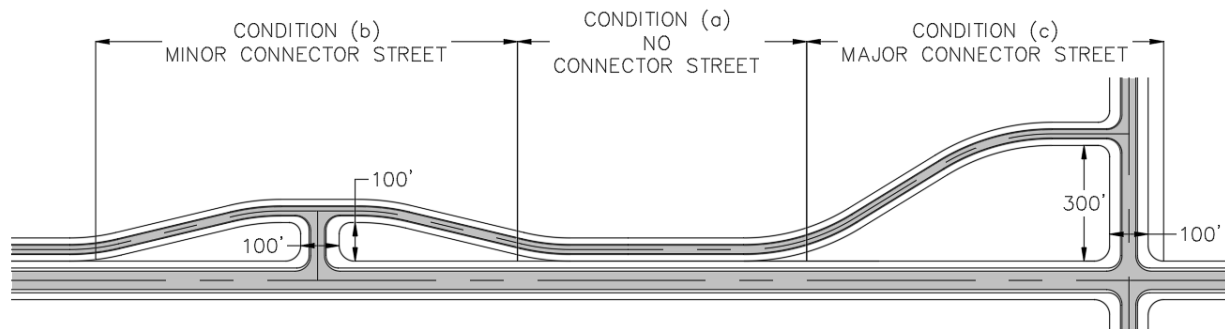

Figure 1: Frontage Street Configurations

Design Standards

- (a) Frontage streets
 - (1) Minimum centerline radii may be reduced near intersections with through connector streets.
- (b) Connector streets – the roadway between major corridor and frontage road.
 - (1) 100-foot ROW width desirable.
 - (2) Minimum 40-foot radius curve returns at the major road corridor.

- (3) Minimum 4-foot-wide shoulders for 100 feet from the edge of roadway of the major road corridor.
- (4) Minimal direct access.

1.6 Design Criteria

1.6.1 General

The ultimate goal in the design of streets is to construct roads that are safe, functional, and durable. The criteria identified in this section are intended to guide the Design Engineer. Specific areas of street design that are discussed include design speeds, lane widths, vertical design requirements, horizontal design requirements, and structural fill requirements. Adherence to these standards or those adopted by reference is required.

For all new roads and road improvements a plan and profile of the road centerline shall be provided, along with other related plans and details, such as culvert plans and details, signage and striping plans, guardrail plans, as necessary to complete the project. Drawings shall be developed in accordance with the standards and formatting used by DOT&PF except where Borough standards drawings are in place. Borough standard drawings, as well as modifications to specifications are maintained by the PD&E Division and are available on the Borough's website. Please, contact the PD&E Division for the latest information.

1.6.2 Design and Posted Speed

Design speeds for different street classifications are provided in Table's 1-3 through 1-5, Design Standards. The objective in design of any engineered facility used by the public is to satisfy the public's demand for service in a safe and economical manner for all users. Therefore, the facility should accommodate as many demands as possible and also should not fail under severe or extreme traffic demands. Roadways should be designed to operate at a speed that satisfies the anticipated need of the users. It is important that the design speed slightly exceed the posted speed on collector streets and roads as this will provide a margin of safety for drivers driving at the speed limit in unfavorable conditions such as inclement weather. Design and posted speeds will vary depending on the purpose of the facility.

1.6.3 Horizontal Design Standards

- (a) Horizontal Alignment. The designer shall follow the horizontal alignment design guidelines outlined in the latest edition of the AASHTO Policy on the Geometric Design of Highways and Streets.
- (b) Superelevation. The maximum cross slope on a super-elevated curve is 6 percent. The impacts of the superelevation on drainage, and access shall also be carefully considered.

1.6.4 Vertical Design Standards

(a) Vertical Alignment (Profile)

The designer shall follow the vertical alignment design guidelines outlined in the latest edition of the AASHTO Policy on the Geometric Design of Highways and Streets. Maximum grades are provided in Tables 1-3 thru 1-5 for the various classifications of roadways.

In areas with flat terrain the road shall be at least 2 feet above the adjacent ground elevation to promote drainage and snow storage.

In areas with frequent winter winds, which typically come from the north to northeast direction, profile elevations should be higher than the adjacent grade by at least 3 feet to promote crosswind scour and minimize the potential for drifting snow to accumulate in the travelled way.

(b) Vertical Curves

Grade breaks are only acceptable when the algebraic difference between the varying street grades is 1.0 percent or less for collector or higher and 2.0 percent for local streets.

Vertical curves should be separated by a tangent grade of at least 25 feet. As a minimum, the design of vertical curves shall use the design speeds established in Tables 1-3 through 1-5.

To minimize drainage problems, the length and location of a vertical curve shall be selected to minimize areas with shallow grades and eliminate areas with flat grades. Sag vertical curves should not be located in cuts to facilitate drainage and snow removal.

The maximum allowable grade through a horizontal curve is 5.0 percent for all road classifications. The maximum road grade above a horizontal curve with a radius less than specified in the AASHTO GB is 5.0 percent for at least 250 feet beyond the point of curvature/tangency to allow for acceleration and braking operations; and only with the installation of appropriate warning signs.

The maximum grade on cul-de-sac bulbs, measured in any direction, is 5.0 percent.

1.6.5 Typical Sections

1.6.5.1 Travelled Way (Lane Width)

The lane width is the travelled way and has an effect on driver comfort and speed and overall road capacity. The desired lane widths for various classifications of roads are provided in Tables 1-4 through 1-6 Design Standards.

1.6.5.2 Shoulder

Shoulders are the portions of the roadway adjacent to, and on the outside edge of, traveled lanes that serve several purposes. The primary purposes they serve may be:

- (a) Space for disabled vehicles or refuge for vehicles that momentarily stop (mail, maintenance, buses, delivery, provide clearance for emergency service vehicle passage).
- (b) Space for evasive maneuvers to avoid encroachment accidents.
- (c) Improved corner sight-distance at intersections and in horizontal curves.
- (d) Improved capacity by allowing uninterrupted flow.
- (e) Space for bicyclists and pedestrians where there are no separate pedestrian facilities.

In order to protect the edge of pavement, the base course shall extend one foot minimum beyond the edge of any paved shoulder and thickened to match the pavement elevation at the edge of pavement. This point may be considered the slope hinge point.

Where bicyclists and pedestrians are to be accommodated, the designer should refer to the AASHTO publication, Guide for the Development of Bicycle Facilities, for additional guidance.

1.6.5.3 Clear Zone

The clear zone begins at the outside edge of the travelled way and is measured horizontally. Minor collector and higher classification roads shall meet clear zone requirements in the DOT&PF Pre-Construction Manual or install the appropriate barrier or other roadside feature in accordance with the AASHTO Roadside Design Guide. Local roadways shall have a minimum clear zone width of 2 feet, unless otherwise approved by the PD&E Engineer.

1.6.5.4 Ditches

Refer to Chapter 3 – Drainage for details on ditches and other roadway drainage requirements.

1.6.5.5 Cut and Fill Slopes

In many cases, road construction requires substantial cut and fill slopes adjacent to the road. The primary concerns on cut and fill slopes are stability and safe access to adjacent property.

In evaluating cut and fill slopes, the maintenance of the slope in terms of mowing and snow removal shall be considered. In some cases, a low retaining wall may be preferable to extensive property re-sloping, particularly if landscaping, fences, or structures would be disturbed. Refer to the Section 1.11.7.5 below for retaining wall requirements. In all cases, the design and locations of the retaining walls must be approved by the PD&E Engineer.

Side slope design shall conform to the clear zone requirements set forth in section 1130 of the PCM and AASHTO Roadside Design Guide, as applicable. Normally, cut and fill slopes shall not exceed 2-foot horizontal to 1-foot vertical ratio. However, the PD&E Engineer may approve steeper slopes if the engineer provides geotechnical, stabilization materials or other information to verify slope stability is adequate.

Appropriate permanent erosion and sediment control measures such as topsoil, seeding, or erosion control matting must be provided beginning at the top of the foreslope point outwards away from the road to original ground for paved roads. For unpaved roads, these measures shall be used after the first 7.5 feet from the shoulder (in fill slopes) or ditch bottom (in cut slopes), outwards away from the road to original ground. Erosion and sediment control concerns are addressed in more detail in Chapter 3 - Drainage.

When cut and fill slopes fall outside of the ROW, a slope easement is required.

When groundwater seepage or aufeis from embankments or cut slopes are observed during the course of project development, whether design or construction, the design engineer shall ensure that adequate controls are implemented to prevent erosion, instability of the road and sloughing of the slopes. Plans revisions may be necessary to mitigate seepage. Increased ditch capacity shall be provided in the drainage design to prevent glaciation issues during the winter months, including but not limited to drainage and encroachment into the roadway.

1.6.5.6 Cross Slopes

The primary function of a cross slope on a street section is to direct drainage to the edge of a street. In most cases, a street is crowned in the middle and slopes to the outside edge. The standard cross slope is 2.0 percent for paved streets and 3.0 percent for recycled asphalt pavement (RAP) streets and for gravel roads.

When super-elevations are being considered, the design guidelines established by AASHTO with a maximum cross slope of 6.0 percent shall be applied.

1.6.6 Intersections

1.6.6.1 Horizontal

- (a) Roads should intersect at an angle as close to 90 degrees as possible but in no event at an angle less than 70 degrees and shall be straight for a minimum of 100 feet from the intersection centerline.
- (b) Where opposing roads intersect with another road and are not in alignment (offset from each other), the opposing roads' centerlines shall be adjusted through geometric realignment and/or ROW acquisition, so that the offset is reduced to 6 feet or less. This is intended to reduce the collision risks associated with conflicts points particularly for left turn movements.

1.6.6.2 Vertical

- (a) The maximum grade on the through street within 50 feet on both sides of a road intersection is 7%, unless otherwise limited by road classification.

- (b) The maximum grade of a controlled street within 30 feet of an intersection is 2.0 percent as measured from the edge of shoulder line of the through street. Landings that slope away from the through street are preferred, however, where this is not feasible due to topographical constraints, the road shall be constructed in a manner that prevents water from flowing onto the through street.
- (c) Match road grades for lower classification roads to the cross slope of the edge of pavement of higher classification road.
- (d) For intersections with curb and gutter, the minimum grade around a curb return or concrete valley gutter is 0.50 percent. The minimum asphalt concrete valley gutter grade is 1.0 percent.
- (e) In the case of intersecting roads with the same functional classification, give preference or primacy in street grades to the road with the higher traffic volume.

1.6.6.3 Curve Returns

Curve Returns. Because the potential for pedestrian and vehicle conflicts is particularly high at street intersections, reduction of potential hazards shall be given careful consideration. In particular, the curve return radius and the length and location of pedestrian crossings must be addressed.

The curve return radius is a function of road classification and design vehicle type. Refer to the design criteria tables for each classification for the respective minimum curve return radius. At intersections of two roads with different classifications, the minimum curve return radius of the higher classified road shall be applied.

In commercial or industrial areas, the above- specified curve radii may need to be increased to accommodate larger vehicles. The design engineer shall verify the curve returns are adequate for the design vehicle using AASHTO templates or turn movement geometry software.

The curve return radii shall provide pedestrian safety that meets the ADA requirements. See section 1.11.8.4 for additional information on accessibility.

1.6.6.4 Intersection Sight Distance

- (a) Whenever a proposed street intersects an existing or proposed street of higher order, the street of lower order shall be made a stop-controlled street, unless alternate intersection control (signal, roundabouts, etc.) is provided.
- (b) Stop controlled streets shall be designed to provide intersection sight distance as specified in this subsection, Table 1-6, and Figure 2.
- (c) The entire area of the intersection sight triangles shown in Figure 2 shall be designed to provide a clear view from point A at 3.5 feet above the roadway to all points 3.5 feet above the roadway along the lane centerlines from point B to point C and point D to point E.

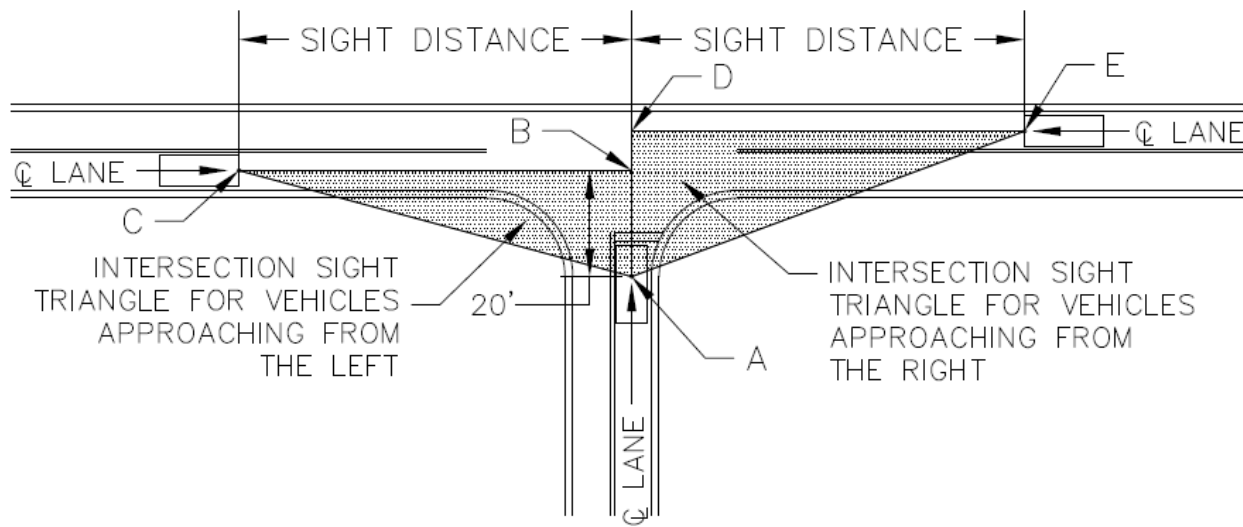

Figure 2: Intersection Sight Distance Triangle

- (d) Sight distances less than the recommended shall only be used when there are topographical or other physical constraints.
- (e) The minimum sight distances listed in Table 1-6 are for a passenger car to turn onto a two-lane undivided road and minor road approach grades of 3 percent or less. For other conditions, the minimum sight distance should be calculated by the applicant's engineer according to A Policy on Geometric Design of Highways and Streets (AASHTO).
- (f) Sight distances less than the minimum, where no other options exist, will require alternate intersection control or warning signs as determined by the design engineer. In no case should the intersection sight distance be less than the stopping sight distance.
- (g) Intersection sight triangles shall be located in their entirety within ROW or a sight distance maintenance easement.
- (h) Yield controlled intersections shall conform to sight distance requirements according to A Policy on Geometric Design of Highways and Streets (AASHTO).
- (i) Intersections within state or other municipal ROW are subject to their respective requirements and review.

Table 1-6: Intersection Sight Distance

Design Speed or Posted Speed Limit (whichever is greater) (mph)	Sd Recommended (ft)	Sd Minimum (ft)
25	370	280
30	450	335
35	580	390
40	750	445
45	950	500
50	1180	555
55	1450	610
60	1750	665
65	2100	720

1.6.7 Auxiliary Lanes

Auxiliary lanes can refer to a number of different types of lane features provided in a roadway or intersection layout, outside the primary travel lanes for through traffic. These include, turn lanes, acceleration/deceleration lanes, climbing lanes, bypass lanes, and others. Refer to the guidance in the “A Policy on Geometric Design of Highways and Streets” (AASHTO). Turn lanes and two-way left turn lanes are the most common types of auxiliary lanes in the MSB, and the following requirements apply to these:

Turn lanes shall be the same width as the travel lanes adjacent to the turn lane or wider.

Two-way-left-turn lanes shall be at least 14 feet wide.

1.6.8 Supplemental Design Elements

Roadways consist of many separate components that are not all applicable in every situation. However, when these elements are used, the following guidelines apply. Specific guidelines for the following components may be found in applicable DOT&PF and/or AASHTO publications. Any variations to the following guidelines must be approved by the PD&E Engineer.

1.6.8.1 Signage

Signs will be designed and placed in conformance with the MUTCD with the Alaska Supplement (latest edition) also referred to as the Alaska Traffic Manual (ATM).

Residential roads within a subdivision will be identified and signed at its point of egress and ingress. Cul-de-sac roads will be signed and identified at their point of ingress according to the MUTCD.

A sign indicating a dead-end road shall be posted on roads with no outlet.

All sign supports will be a minimum of 12-gage, .105" wall thickness, perforated steel tubes, 2½" square. Reference DOT&PF Standard Drawing S-30.03 Light Sign Structure Post Embedment, Concrete Foundation. The supports and foundations of larger signs will conform to the MUTCD.

Sign offsets shall be as per DOT&PF Standard Drawing S-05.01 Post Mounted Sign Offset and Height.

1.6.8.2 Striping

In the MSB, there are different levels and types of roadway striping are required depending on classification and traffic volume. Refer to tables 1-4 thru 1-6 for MSB requirements for striping on paved Borough roads. All striping shall be done in conformance with the MUTCD, latest edition.

1.6.8.3 Curb and Gutter

Curb and gutter are mainly used for medians and at intersections with pedestrian amenities on Borough roads. Otherwise, curb and gutter are generally discouraged on the outside edge of Borough roads for stormwater management and maintenance purposes. In areas where curb and gutter is installed, stormwater outlets such as catch basins or curb cuts, shall be installed with a maximum separation of 300 feet between the outlets.

The following types of curbs are installed in the MSB:

- (a) Expressway curb and gutter shall be used on medians, traffic islands, and roundabouts.
- (b) Mountable curb and gutter are used, if installed, at pathway intersections on major collector roads, local commercial and industrial roads.
- (c) Rolled curb and gutter shall be used, if installed, at pathway intersections between local or minor collector roads.
- (d) Vertical curb shall be used at intersections with pedestrian amenities on local roads only. Vertical curb shall not be used along high-speed roadways (design speeds equal to or greater than 40 mph).

All curb and gutter designs must meet clear zones requirements.

1.6.8.4 Curb Cuts

Curb cuts may be used at low points in the roadway vertical profile to facilitate drainage to roadside ditches. Refer to DOT/PF Standard Drawings for proper design of curb cuts.

1.6.8.5 Medians

The primary function of a roadway median is to separate opposing traffic movements and control left-turn movements. Medians may also serve to provide refuge for pedestrians, manage access and turn movements, and/or enhance aesthetics with landscaping. The use of medians requires approval by the PD&E Engineer.

The following criteria apply to median design:

The minimum width of a raised median is 4 feet from face of curb to face of curb.

Raised medians on high-speed roadways, typically major collector and above, shall be constructed of mountable curb and gutter.

Median noses shall be depressed to reduce safety hazards for oncoming traffic and to safely accommodate maintenance vehicle movements.

A raised median that separates a left-turn lane from the opposing traffic shall extend the full length of the left-turn pocket.

Refer to DOT/PF Standard Drawings for proper design of raised medians.

1.6.8.6 Guardrails

Guardrails warrants and location shall be determined in accordance with the AASHTO Roadside Design Guide. Refer to DOT&PF Standard Drawings for guardrail details.

1.6.8.7 Retaining Structures (Non-bridge)

In some cases, roadway design cannot avoid use of retaining structures to support the roadway or pathway features or a cut/fill bank. Where no alternative solutions exist, materials that are resistant to deterioration and provide for cost-effective construction shall be incorporated into the design. All available design alternatives to reduce the necessity for installing retaining structures shall be considered. Adequate drainage must be provided behind the structure. A registered engineer must prepare and seal the design of all retaining structures, unless the DOT&PF standard drawing is used. All retaining wall designs shall be reviewed and approved by the MSB.

This section details the design requirements for retaining walls that do not support bridges or wingwall structures related to bridges and the designer should use the recommendations provided in Chapter 2 of the DCM. The design of retaining structures containing exposed heights, H, equal to and between 4 and 20 feet shall meet the requirements outlined in Table 1-7. All walls with an exposed height of over 20 feet shall be designed in accordance with Chapter 11 of the current AASHTO LRFD Bridge Design Specifications.

Table 1-7: Summary of Design Standards for Retaining Walls*

Roadway Classification	Permanent Non-critical Stabilization; 20 ft > H > 4 ft	Permanent Critical Stabilization; 20 ft > H > 4 ft
Definition	Supports slopes adjacent to roadway where minimal risk of impact to human safety or property would occur during or after failure.	Directly supports the traveled way or roadway shoulder and presents substantial risk to human safety during or after failure.
Collector and Above	Chapter 11 of the current AASHTO LRFD Bridge Design Specifications**	Chapter 11 of the current AASHTO LRFD Bridge Design Specifications
Residential and Below	Chapter 11 of the USFS Low Volume Roads BMPs***	Chapter 11 of the current AASHTO LRFD Bridge Design Specifications**

*See Chapter 2 for wall requirements that support bridges.

**Not required to meet seismic design criteria.

***https://www.fs.usda.gov/t-d/programs/forest_mgmt/projects/lowvolroads/ch11.pdf

1.6.9 Pedestrian Facilities

Pathways and sidewalks shall be designed according to AASHTO Guide for the Planning, Design, and Operation of Pedestrian Facilities, the 2010 American with Disabilities Act Standards for Accessible Design, and the requirements of this section.

1.6.9.1 Multi-Use Pathways

Multi-use pathways shall be paved and preferably have a width of 10 feet with an additional one foot of unpaved shoulder on each side. The paved width may be reduced to a minimum of 8 feet, in locations where ROW or physical constraints prohibit. Pathway surfaces shall be constructed with asphalt, except at signalized intersections, roundabouts or other locations where concrete is more appropriate. Pathway intersection crossings shall be designed in accordance with the standard drawing by DOT&PF Central Region.

Separation distance between the pathway and roadway shall be in accordance with 1.6.9.3. Placement of the roadside ditch between the road and pathway is preferable for pathway drainage and maintenance.

Pathway alignments do not need to closely parallel the roadway alignment or follow the same profile and should be separated from the road as far as the ROW and utilities allow. Plan drawings showing a plan and profile for the pathway separate from the road plan and profile should be developed for all pathways improvements. Replacements for existing multi-use pathways shall be of equal or better construction and shall not be reduced in size or separation distance.

All pathways shall be signed for “NO MOTOR VEHICLES” to support pedestrian safety and enforcement efforts.

1.6.9.2 Sidewalks

Sidewalks are generally not used on Borough roads, except along some local roads where significant pedestrian traffic is expected. Sidewalks should be at least 5 feet wide and have a surface of asphalt or concrete. The installation of curb and gutter for sidewalks is not required and should consider the impacts of stormwater discussed in section 1.6.8.1.

1.6.9.3 Pedestrian/Vehicle Separations

Pathways and sidewalks shall be separated from roadway traffic for safety, user comfort and snow removal, except at intersections, where the pathway shall taper toward the road for the crossing. The separation distance from edge of road shoulder pavement to edge of pathway shall be 10 feet or more on all roads classified as collector and above. In areas where 10 feet of separation is impractical due to physical constraints (bridges, underpasses, waterbody crossings, etc.), or where ROW is unavailable for purchase, and the posted speed is equal to or less than 35 mph, the pathway separation may be reduced to 5 feet. In these cases, a physical barricade for pathway user safety shall be considered. Pathway separation shall not be reduced due to utility conflicts, or to avoid ROW acquisition.

Separation distance for pathways and sidewalks on local roads may be reduced to 5 feet due to ROW constraints.

1.6.9.4 Accessibility Requirements

All new construction and alterations within the MSB ROW must be designed to be accessible for all pedestrians in accordance with the ADA when applicable. The complete Americans with Disabilities Act Accessibility Guidelines (ADAAG), which is part of the regulations enforcing ADA, is available online from the U.S. Architectural and Transportation Barriers Compliance Board (Access Board) at www.access-board.gov.

Designs that include pedestrian facilities within MSB ROW shall conform to the version of ADA Guidelines for Accessible Public Rights-of-Way in effect at the time of submittal.

The following are examples of some design elements covered under current ADAAG:

New or widened road - all pedestrian elements, including curb ramps, sidewalk cross slope, driveway cross slope, clearance around utilities, pedestrian access to adjacent commercial properties, and accessible pedestrian construction detours.

Roadway surface rehabilitation only - new and complying curb ramp for every road crossing that has both sidewalk and curb, unless there is an existing curb ramp that meets all ADA standards.

1.6.10 Access Points

1.6.10.1 Access Point Spacing

The design of access points along a roadway should comply with the roadway or corridor access management plan where one exists. Refer to MSB Planning Code for a list of adopted access management plans. Otherwise access spacing shall meet or exceed the standards provided in Table 1-8 below:

Table 1-8: Minimum Average Access point Spacing

Posted Speed Limit (mph)	Minimum Average Access Point Spacing per Mile (feet)
30	250
35	300
40	360
45	425
50	495
55	570

1.6.10.2 State Highways

Access to state highways is regulated by DOT&PF. Driveway and encroachment permits for access to state highways are available from DOT&PF, and it is the responsibility of the project to obtain permits whenever construction within DOT&PF ROW is anticipated.

1.6.10.3 Borough Roads

Access to Borough roads is regulated by the Borough. Driveway and encroachment permits for access to Borough roads are available from the Planning Department's Permit Center, and it is the responsibility of the project to obtain permits whenever construction within Borough ROW is anticipated.

Refer to MSB code 11.12 for driveway standards and permitting requirements.

All connections to Borough Roads must be authorized by the Permit Center prior to construction.

1.6.11 Utilities

All potential utility companies must be involved in the early stages of a project's development. When existing utilities conflict with proposed road improvements, the designer must analyze the alternatives available for resolving the conflict early in the design study or preliminary design efforts. If the analysis indicates the need for relocation, the relocation efforts shall be accomplished in accordance with MSB Title 11. The Utility must be involved at every stage of the design and relocation. A Utility Agreement shall be executed by the owner and utility company for utility relocations with an estimated cost of

\$25,000 or more for a single utility. The Utility Agreement template available from the PD&E Division shall be used for Borough projects, as required.

The location of utilities within established utility easements is encouraged wherever possible. A fifteen-foot utility easement is typically needed outside both sides of the road right of way to allow for utility installation and maintenance. Easements should be clear of wells, septic systems, homes, decks, buildings or other structures, unless the owner has obtained a "Non-Objection to Easement Encroachment" from the utilities. Utility easements are to be fully useable for utility installation where installation equipment can safely work.

Utility facilities paralleling the ditch line may not be placed closer than four feet from the ditch bottom.

No shallow utility installation paralleling the road surface will be allowed within the road surface or shoulder areas due to road compaction and/or designated fill requirements.

This restriction is not applicable to underground road crossings.

1.6.12 Lighting

Lighting on Borough roads is generally limited to intersections of collector roads and above. Due to its rural setting and large number of road miles with low traffic volumes, it is not necessary, desirable or practical to illuminate the majority of roads other than those with high volumes, most of which are operated by DOT&PF. This policy is meant to minimize most traffic accidents, which occur at intersection while controlling Borough operating and maintenance costs. It is also intended to minimize impacts to drivers' night vision and general light pollution.

The typical form of intersection lighting at MSB intersections is installation of a single luminaire on a wooden utility pole owned by either MEA or the MSB and maintained by the Matanuska Electric Association (MEA). Maintenance and electricity usage is accounted for and paid through a Borough agreement with MEA. Additions of new luminaires to existing or new utility poles should be coordinated with MEA as part of utility coordination and agreement.

On occasions, where a single MEA pole is not adequate, such as signals, roundabouts, or high-speed turn lanes, steel pole luminaires shall be designed and installed in accordance with DOT&PF standards. To minimize operating and maintenance costs, light emitting diodes (LED) lights are preferred, and should be designed with a color temperature of 3000 degrees Kelvin or less to protect driver night vision. When possible, luminaire poles shall be installed outside the clear zone. When installed within the clear zone, any new poles must be installed with breakaway bases. New lights can be installed on existing poles if the poles are in a permitted location.

1.6.13 Mailbox Pullouts

Mailbox pullouts shall be constructed with the same structural section as the adjacent roadway and sized as follows:

- Length 20 feet

- Width 10 ft
- Entrance and exit taper – 2:1 for local roads (25 mph posted speed). Refer to Roadside Design Guide for higher speed roads.

Sufficient line of sight must be available from both directions of travel. Refer to the MSB standard drawing for mailboxes for more information.

1.6.14 Geotechnical Information

This section is meant to provide a consistent approach towards soils investigation leading to competent roadway structural design.

A Soils Investigation Report shall be prepared for new construction and reconstruction projects on roadways with a functional classification of Minor Collector or higher, local commercial roadways, and all drainage projects. For other types of projects, the requirement for a Soils Investigation Report will be determined during project scoping. The primary purpose of the report is to provide information on the engineering properties of the subsurface soils, water table, and moisture conditions throughout the project.

The designer shall present a soils investigation plan for approval by the PD&E Engineer prior to conducting field investigations. Once soils have been sampled and analyzed the designer shall submit a Soils Investigation Report. The geotechnical work shall generally follow the practices and procedure as outlined in the Alaska Geotechnical Procedures Manual, unless otherwise directed by the PD&E Engineer.

1.6.15 Requirements for Paved Streets

When paving is to be performed on existing Borough roads, the existing subbase will be reviewed for gradation and frost susceptibility. Appropriate measures will be taken to upgrade the existing road to ensure the best possible design life of the paved surface.

For local roads, the pavement must be an approved Type II mix design with a minimum 2-inch thickness.

Primary roads, such as collectors and arterials, may require a pavement thickness of 3 and 4 inches, respectively. Structural pavement design calculations shall be submitted to the PD&E Engineer to substantiate pavement thickness early in the design process, once traffic volumes are known.

1.6.16 Insulation

Insulation may be used in the construction of streets where the subgrade is determined to be frost-susceptible and reduction in the depth of the gravel backfill, as required by the Limited Frost Penetration Method, is desired for economic reasons. The use of insulation is not intended to prevent the freezing front from reaching the subgrade; it is intended to minimize the depth of subgrade freezing below the borrow material by providing partial thermal protection and a more uniform freezing depth. Other

factors, such as the interception and removal of water by a drainage system, are also important and are covered in Chapter 2 of this manual.

The DOT&PF Standard Specifications establishes standard construction specifications for improvements that use insulation within the street ROW.

Research conducted by DOT&PF has shown the following to be acceptable guidelines for the use of rigid insulation:

1. Use of only high-density polystyrene board with a minimum compressive strength of 60 pounds per square inch and a maximum water absorption of 0.10 by volume;
2. Placement of a minimum cover of 18 inches of gravel fill over the insulation to protect the insulation from heavy wheel loads during construction and to minimize frost formation on the pavement surface;
3. Extending the limits of the insulated section adequately beyond the heave zone to avoid causing bumps where the frost-susceptible material is not insulated. In addition, if more than one layer of boards is used, insulation thickness shall be gradually stepped down.

1.6.17 Right-of-Way

Many MSB infrastructure projects require acquisition of some form of public ROW. The MSB prefers to acquire fee simple ROW for roadways, but also acquires easements for many different purposes, including, but not limited to, temporary construction, slope and maintenance, drainage, access and public use. Guidance for the ROW process should generally follow the same procedures used by the DOT&PF.

When preparing parcel plats used for fee simple and easements, surveyors should use the MSB Acquisition Checklist and example exhibits included in Appendix A of this section.

Appendix A

MSB ACQUISITION EXHIBIT CHECKLIST

MSB ACQUISITION EXHIBIT CHECKLIST

Use 8 ½" x 11" or 8 ½" x 14" paper. The plats must be neat, legible, accurately dimensioned, and exhibit enough contrast so that copies made by the recording office leave no question as to the location of the property being transferred.

1. Line work for Right of Way (ROW) Centerline.
2. Line work for subdivision and/or aliquot parts as per Title Report:
 - a. Adjacent lots dashed lines within 50-100 feet.
 - b. Parent Parcel bold solid lines.
3. Acquisition line work (bold dashed line for Easements - bold solid lines for Fee).
4. Pick Scale to show remainder if possible, or use second Page at a different scale.
5. Remove all Distance and Bearings on adjacent lots or areas.
6. Show Existing Improvements within 25 feet of existing and proposed ROW.
7. Show and label existing easements on parent parcel, and within 100' on adjacent parcels, with dashed line work (Dimension, type, and include record information if not dedicated on plat of record).
8. Show all curve data and centerline stationing with tick marks, if available. **NOTE:** The parcel map examples do not show centerline stationing.
9. Label existing improvements and ties to proposed and existing ROW dimensioned to 0.1 foot with no +/- (e.g.: see well on exhibit).
10. Label source of existing ROW (Dimension, type, and include record information if not dedicated on plat of record).
11. Label Subdivision Name or Names including Plat Number with a solid font; if plat has been re-recorded show both plat numbers, including adjacent lots if Subdivision Name and Plat Number are different than subject parcel.
12. Label Lot numbers and Block numbers, including adjacent lots.
13. Label Street Names including directional.
14. Label Acquisition Area.
15. Label Project Right of Way line.
16. Label at top of drawing: Exhibit "A".
17. Label Parcel Number. If fee and easement required on same parent parcel, label as "Parcel 10" for Fee and "Parcel E-10" for Easement. If the use of temporary construction permit (TCP) or temporary construction easement (TCE), prefix the areas required by the letters "TCP" or "TCE" followed by the number assigned to the parcel. Use the same process for slope & maintenance easement (SME) or creek and maintenance easement (CME).
18. Dimension:
 - a. Parent Parcel – Measured and Record.
 - b. Acquisition.
 - c. Acquisition dimension ties to property corners.
 - d. ROW width where parallel to centerline.
 - e. Segmented distances should add up to the overall distance. Overall Distance should be located on the outside of the parent parcel boundary line and the segmented distances should be on the inside of the parent parcel. Use leader lines as needed.
 - f. Curve Table Elements: Curve#/Length/Radius/Delta/Chord Bearing/Chord Length.
19. Hatch existing ROW and Acquisition Areas and include Hatches in Legend:
 - a. Acquisition areas – Dots.
 - b. Existing Public and Private ROW and Easements – ANSI31.
20. Title Block:
 - a. Easement Area (Gross, Net, and Remainder when Fee).
 - b. Scale notation.
 - c. Date (Save Date-update date every revision).

Parcel No.: _____

Project Name

Project Number

- d. Parcel Number.
 - e. Project Number.
 - f. Project Name.
 - g. Tax Account Number.
 - h. Surveyor's printed name, address, phone number, and AEC number.
 - i. Legal Description including Section, Township, Range, Meridian, Recording District, Third Judicial District, and State of Alaska.
 - j. Page Numbers.
-
- 21. Show Land Hooks where needed.
 - 22. Basis of Bearings note.
 - 23. Type and Size of all monuments found or set.
 - 24. Seal, Sign, and Date.

EXHIBIT "A"

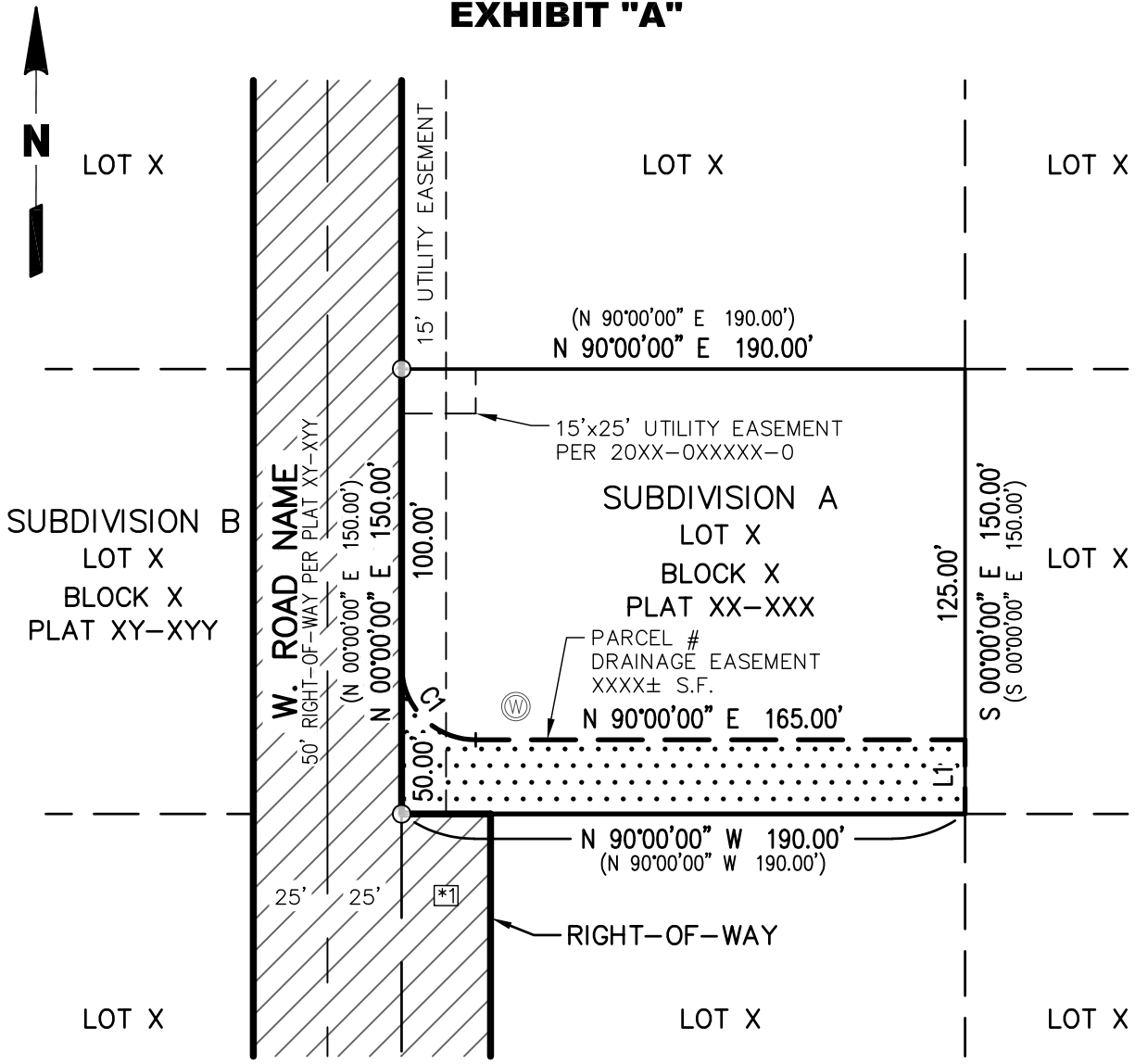

CURVE TABLE					
CURVE	LENGTH	RADIUS	DELTA	CHORD BEARING	CHORD LENGTH
C1	39.27'	25.00'	90°00'00"	S 45°00'00" E	35.36'

NOTES:
 1. BASIS OF BEARING IS NAD 83(2011) ALASKA STATE PLANE, ZONE 4.

LINE TABLE		
LINE	DIRECTION	LENGTH
L1	S 00°00'00" E	25.00'

RIGHT-OF-WAY LEGEND:
 *1 - 30' RIGHT OF WAY DEED PER 20XX-0XXXXX-0

- LEGEND**
- () RECORD DATA PER PLAT XX-XXX
 - FOUND "X" X
 - EXISTING RIGHT-OF-WAY
 - EASEMENT REQUIRED
 - WATER WELL



MATANUSKA-SUSITNA BOROUGH
 PUBLIC WORKS DEPARTMENT

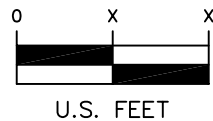

NAME, ADDRESS, CITY, AK, ZIP, PHONE

DRAINAGE EASEMENT REQUIRED FOR: PROJECT NAME LOT X, BLOCK X SUBDIVISION A PLAT X, LOCATED WITHIN SECTION X, T X N, R X W, X MERIDIAN X RECORDING DISTRICT, THIRD JUDICIAL DISTRICT, STATE OF ALASKA	EASEMENT AREA: X,XXX S.F.	DRAWN BY: XXX
	TAX ACCOUNT No: XXXXBXXLXXX	CHECKED BY: XXX
	TAX MAP: XXXX	PARCEL No.: X
	PROJECT No.: X	SCALE: 1"=X'
	DATE: 4/2/2024	PAGE: 1 OF 1

EXHIBIT "A"

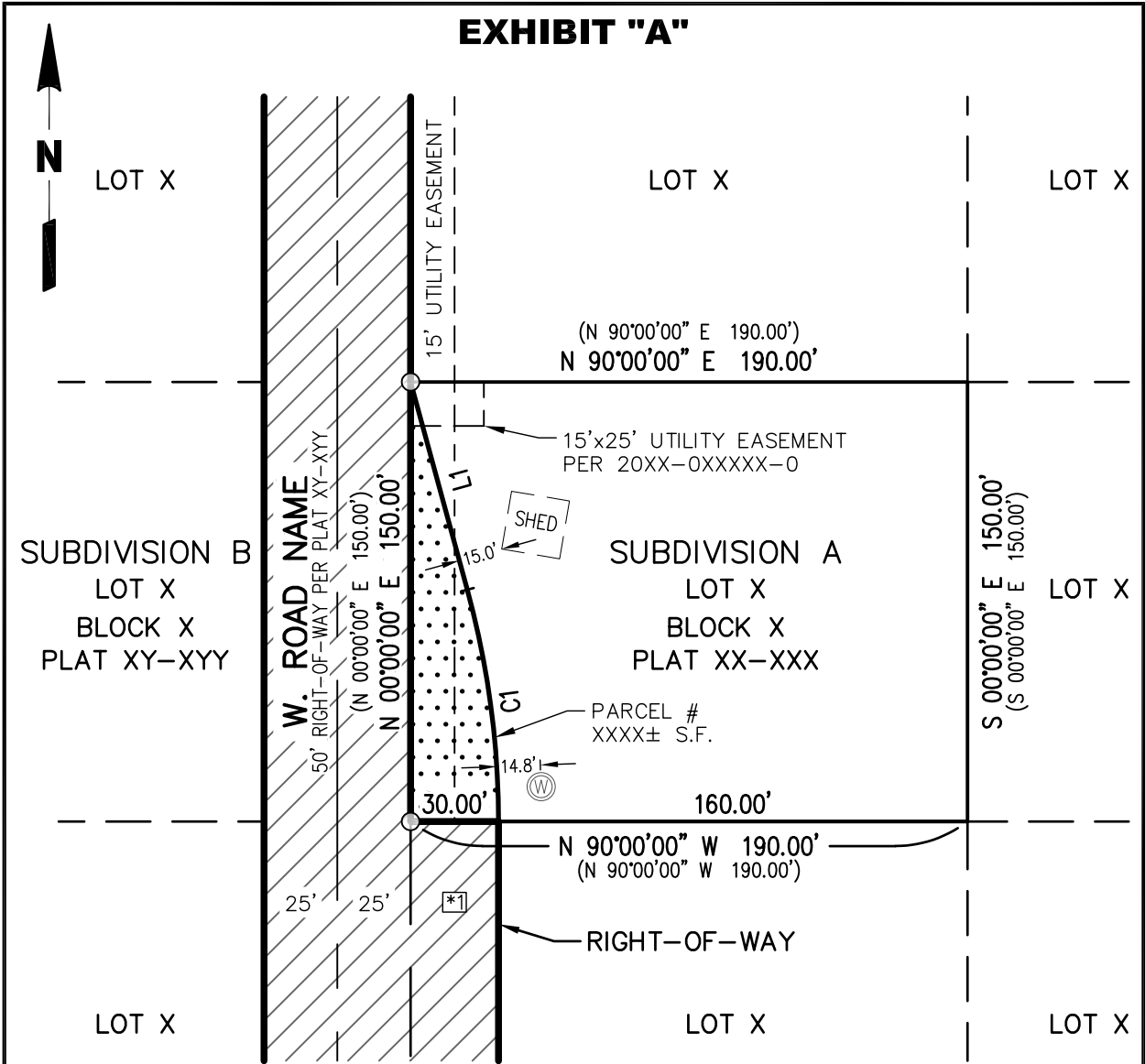

CURVE TABLE					
CURVE	LENGTH	RADIUS	DELTA	CHORD BEARING	CHORD LENGTH
C1	80.06'	300.00'	15°17'28"	S 7°38'44" E	79.83'

NOTES:

1. BASIS OF BEARING IS NAD 83(2011) ALASKA STATE PLANE, ZONE 4.

LINE TABLE		
LINE	DIRECTION	LENGTH
L1	S 15°17'28" E	73.48'

RIGHT-OF-WAY LEGEND:

*1 - 30' RIGHT OF WAY DEED PER 20XX-0XXXXX-0

LEGEND

- () RECORD DATA PER PLAT XX-XXX
- FOUND "X" X
- EXISTING RIGHT-OF-WAY
- RIGHT-OF-WAY REQUIRED
- AREA REMAINING
- WATER WELL



MATANUSKA-SUSITNA BOROUGH
PUBLIC WORKS DEPARTMENT

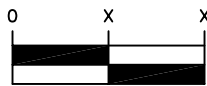

U.S. FEET

AEC #XX
NAME, ADDRESS, CITY, AK, ZIP, PHONE

RIGHT-OF-WAY REQUIRED FOR: PROJECT NAME LOT X, BLOCK X SUBDIVISION A PLAT X, LOCATED WITHIN SECTION X, T X N, R X W, X MERIDIAN X RECORDING DISTRICT, THIRD JUDICIAL DISTRICT, STATE OF ALASKA	GROSS AREA: X,XXX S.F.	DRAWN BY: XXX
	NET AREA: X,XXX S.F.	CHECKED BY: XXX
	REMAINDER: X,XXX S.F.	TAX MAP: XXXX
	TAX ACCOUNT No: XXXXBXXLXXX	PARCEL No.: X
	PROJECT No.: X	SCALE: 1"=X'
	DATE: 4/2/2024	PAGE: 1 OF 1